



Autmix[®]

INDUSTRIAL
GROUP

General brochure



Contents

Autmix Group	4		
Solutions	6		
Industries	8		
Flow	10	Industrial IT	32
Available configurations	12	System and application design	35
Products	14	Industrial networks and virtualization	36
R&D	16	Cybersecurity	38
Consulting in physical analysis	17	Productivity	40
Process	18		
Automation and control systems	20		
Mechanical design	22		
Electrical design	23		
Turnkey projects	24		
Collaboration with OEMs,	28		
engineering and integrators			
Industrial automation consulting	30		



We help companies to streamline and optimize their production processes



We are an industrial group specialized in various branches of engineering, with an enormous willingness to help you meet your goals.

Through the use and creation of high technology, we develop industrial solutions with tailored products and services.

International coverage. Our headquarters and main manufacturing point are in Mexico, and we have offices in the United States, Spain and France.





We develop high value-added solutions for each industrial sector

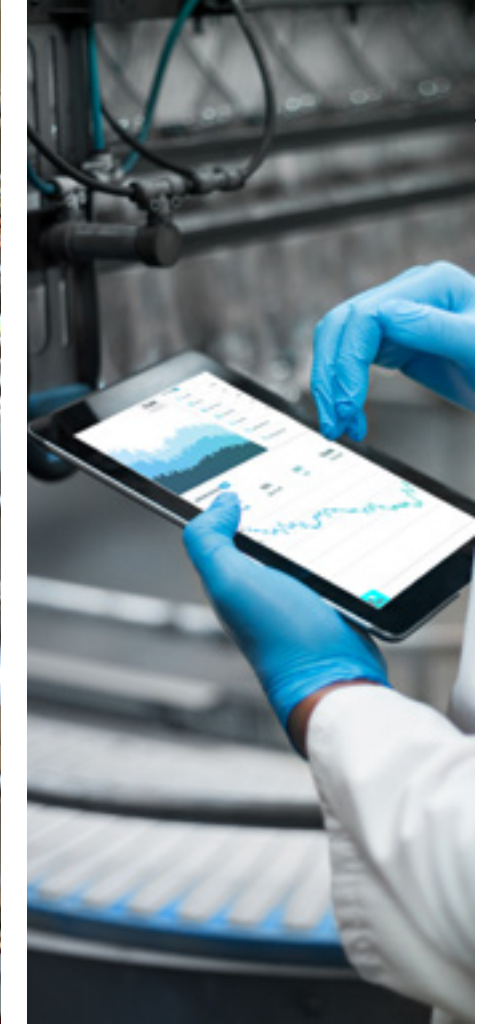
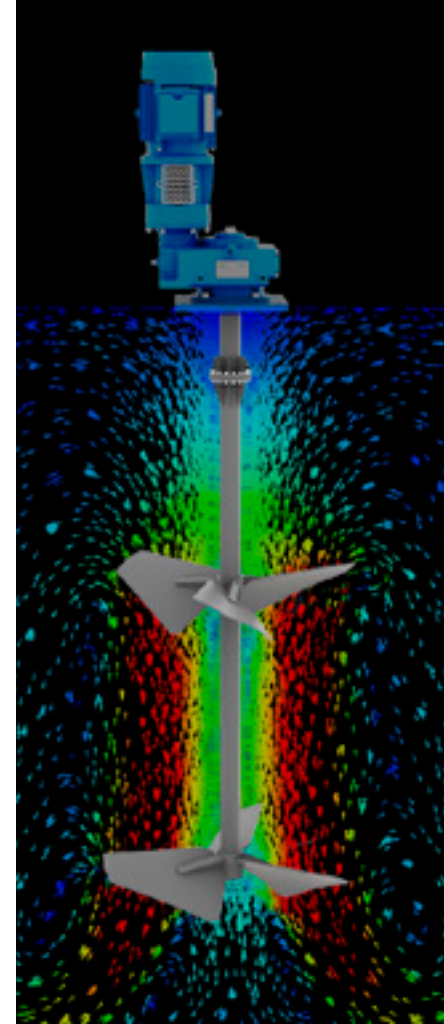

Autmix[®]Flow
MIXING SOLUTIONS

Design and manufacture of agitation and mixing technology.



Autmix[®]Process
ENGINEERING SOLUTIONS

Process engineering and consulting.



Autmix[®]Industrial IT
INFORMATICS SOLUTIONS

Integration of industrial information systems.

Industries



Food and beverage



Pharmaceutical



Cosmetic



Chemical



Mining



Oil and gas



Water treatment



Sugar



Paint



Paper



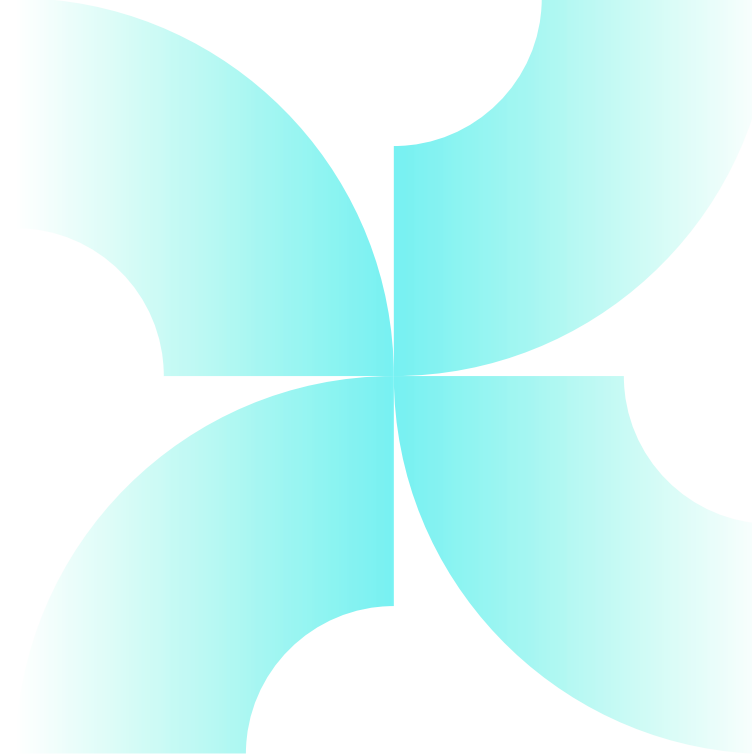

Autmix Flow

Industrial mixing
and agitation solutions

We offer top quality solutions in achieving therefore guaranteeing the different stirring and mixing a high profitability in each project processes for various industries. and a fast return on investment. The modularity of the design of our equipment, allows us to always adapt to customer needs,

Liquid - Liquid



Homogenization
Emulsion
Neutralization

Liquid - Gas











Dispersion
Dissolution

Liquid - Solid



Suspension
Coagulation
Crystallization

Advantages

-  **Custom design.**
According to project specifications.
-  **Top quality materials.**
From top brands.
-  **Highly competitive prices.**
-  **Delivery time punctuality.**
-  **Extensive equipment warranty.**
-  **After-sales service.**
Spare parts for immediate delivery.
-  **Specialized and skilled technical support.**
-  **Cutting-edge technology design and simulation tools.**

Over 5000 available configurations

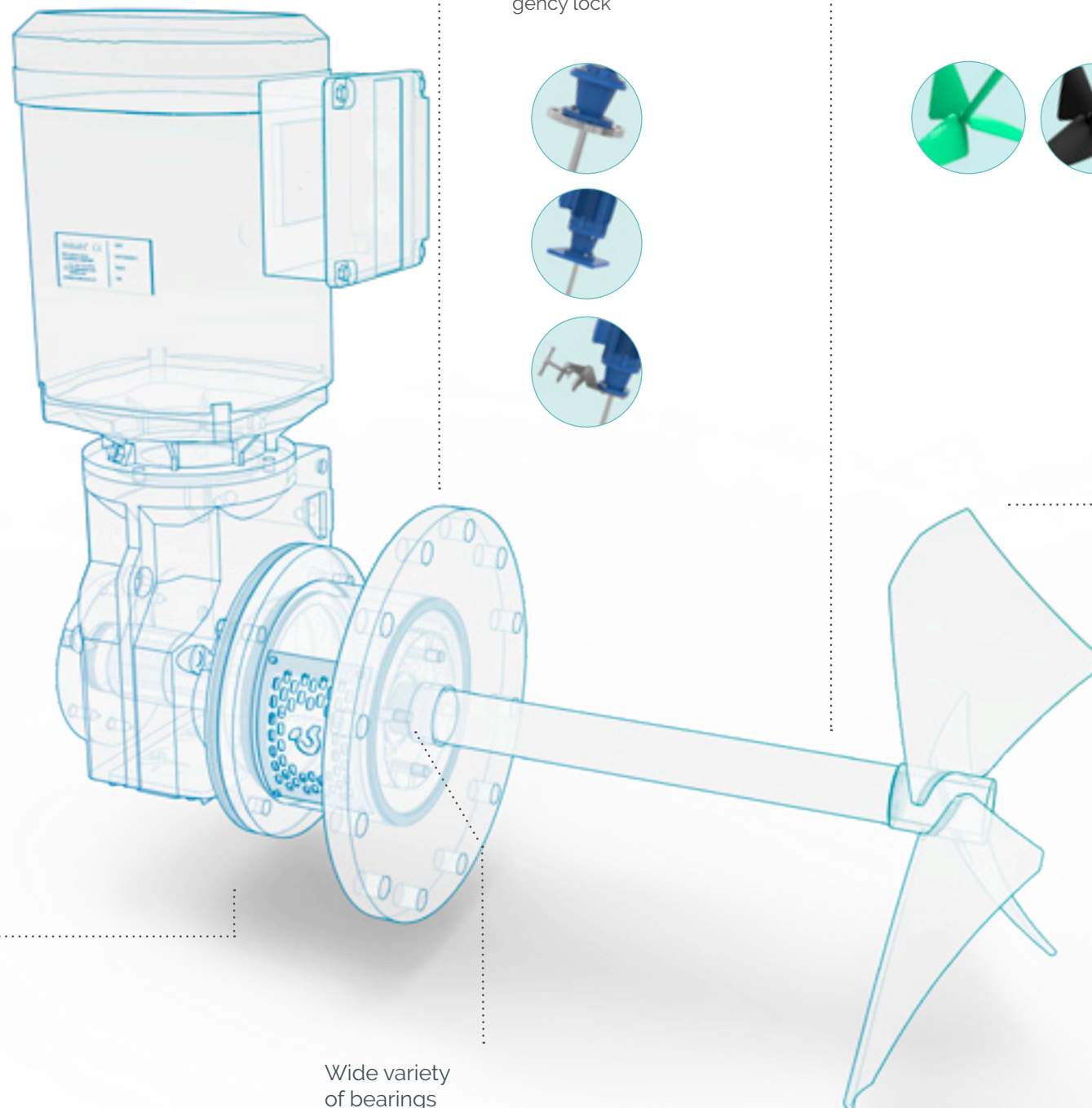

Optional

- Engines with ATEX certification against explosive areas
- Special certifications (NOM)

Sealing system

- Simple seals or double lip seals
- Hydraulic labyrinth
- Cable glands
- Simple mechanical seal
- Double mechanical seal
- Autonomous cooling system (thermosyphon)
- Vapor barrier
- Cartridge with double mechanical lock
- Disassembly with pressure reactor

Wide variety of bearings

Clamping

- ANSI or DIN flange
- Square plate
- Clamping by clamp
- Flange with emergency lock



Coatings

- PTFE
- PVDF
- EPDM
- Halar
- Butyl rubber
- Ebonite
- Fiberglass
- Special coatings



Manufacturing materials

- Carbon steel
- AISI 304
- AISI 316L
- Duplex
- Super Duplex
- Uranus B6
- Titanium
- Hastelloy

Finishes

- Sanitary polishing
- Specification of roughness



Impeller

- Sabre
- Nabla
- Gamma
- Stokes
- Cowles
- Marine
- Helical anchor
- Axial turbine
- Radial turbine
- Double flow
- Rushton
- Standard anchor



Products

RT



Vertical mixers RT

High energy performance equipment, high efficiency mixing, for any type of industry.

NC



Anchor mixers NC

Used to avoid stagnation; maintain fluid motion with high viscosity.

ZB



Horizontal and bottom mixers ZB

Efficiency in a wide range of processes with an excellent sealing system; keeps the fluid inside the container.

CT



Compact mixers CT

Developed to rotate at high revolutions per minute in low volume processes.

↑
↓



Elevation systems

Platform with anchoring to the floor or impeller. Electric, pneumatic or manual drive.

↺
↻



Polyelectrolyte dosing systems

An ideal option for your processes for separating particles and compounds, purify liquids or generating effects in solutions.

R&D Research & Development

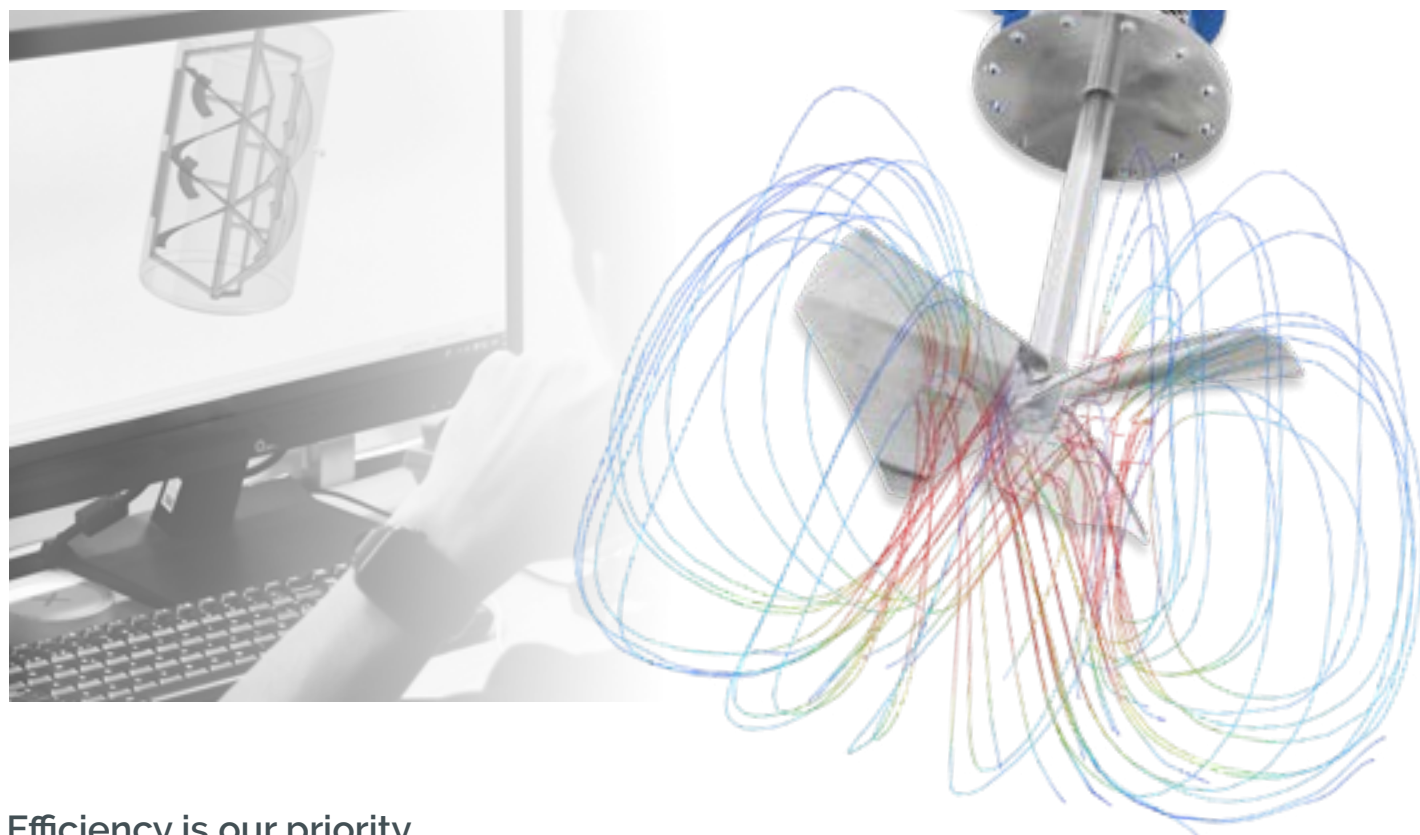

Efficiency is our priority.

For this reason, our Research and Development department is constantly dedicated to improving and creating new products from processes based on the scientific method. By using the most advanced mathematical modeling tools, along with CFD (Computer Fluid Dynamics) and FEA (Finite Element Analysis) simulations, it is possible to analyze and interpret very precise data of the flow patterns of fluid behavior and the integration of the different components necessary to meet the objective of the proposed agitation.

Consulting in analysis of physical systems

✓	✓	✓
Obtaining process variables with very high precision and reliability.	Verification of resistance of materials prior to manufacture.	Vibration and resonance analysis.
✓	✓	✓
Optimization of consumption ratios.	Ease of visualization of flow behavior patterns.	Validation for the development of new equipment and mechanisms.
✓		
Heat transfer studies.		

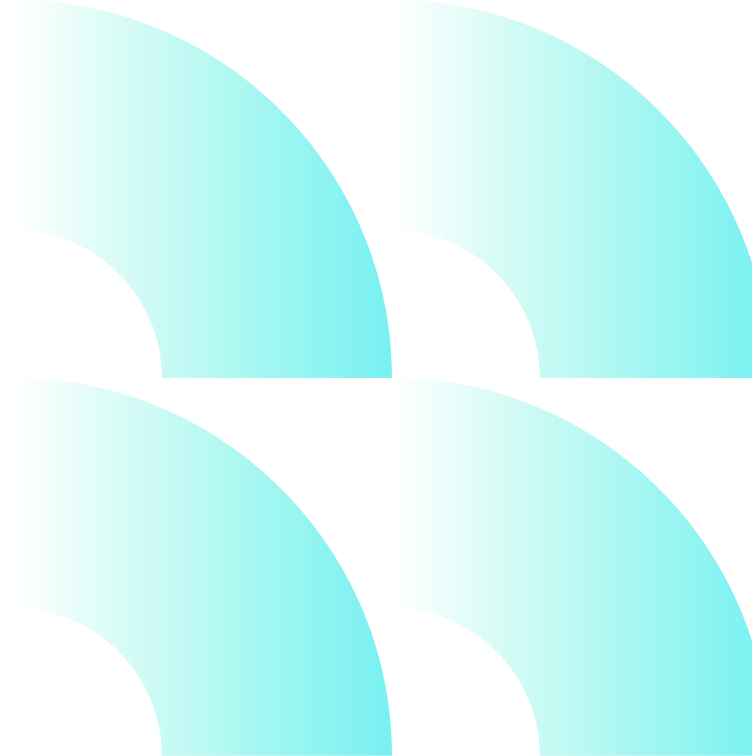
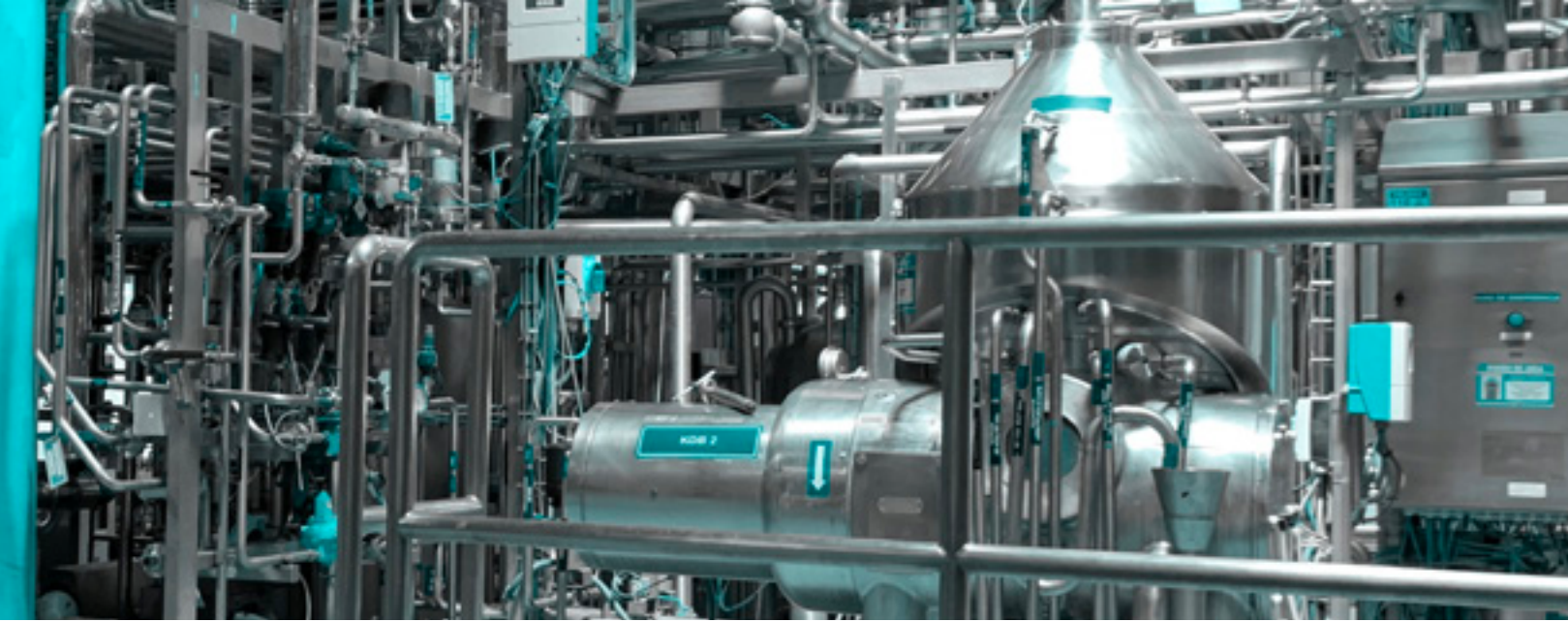

Autmix Process

Process engineering solutions

We integrate industrial automation and mechanical and electrical engineering to offer a general improvement in your industry, saving time, effort and money with the appropriate facilities for each process.

Our goal is to work with the highest quality standards and provide the best service to optimize material and human resources in industries.

Advantages



Professional counseling



Solutions tailored to needs



High quality equipment



Specialized technical support



Automation and control systems

We apply supervision, control and data acquisition systems that allow users to interact with operational processes in a comfortable, safe and efficient way.

We create custom process automation according to the needs of our clients. In this way, we guarantee a complete integration between SCADA systems, PLCs, traceability and reporting. With these services, your factory will benefit, optimizing raw materials and production times; In addition, we ensure an increase in the safety of the company's personnel and savings derived from production efficiency. We have highly qualified personnel for design, engineering and execution, dedicated to ensuring that projects are delivered on time and with the best quality.

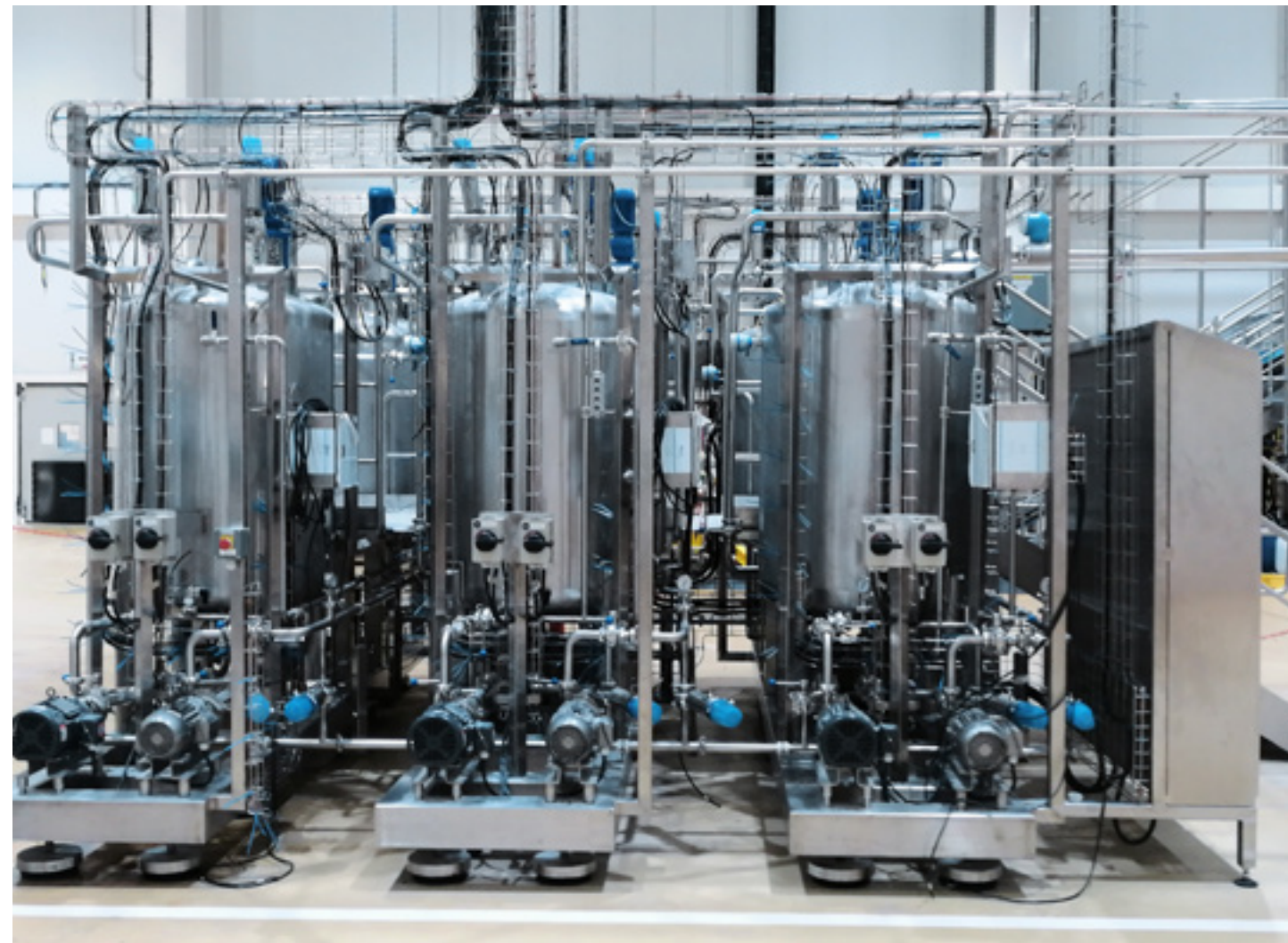

Batch processing

We use and integrate different software alternatives for the adequate automation of batch and continuous process manufacturing companies.

- Factory Talk Batch
- Wonderware Batch Management
- Simatic Batch.

SIEMENS

RA Rockwell Automation

Wonderware
by AVEVA

ABB

Distributor
Automation & Controls

MITSUBISHI ELECTRIC

Schneider Electric

Honeywell



Mechanical design

Start your project with the best equipment and ensure production in your manufacturing line.

During the engineering development we take into account each process variable, in order to guarantee the safety and correct operation of your systems.



Design of piping and instrumentation diagrams.



Process installation calculation using advanced simulation software.



Mechanical studies for pipe systems, heat exchangers, tanks and structures.



Assembly and commissioning.



Modular process skids solutions design.



Design and 3D modeling.



Head loss calculation.

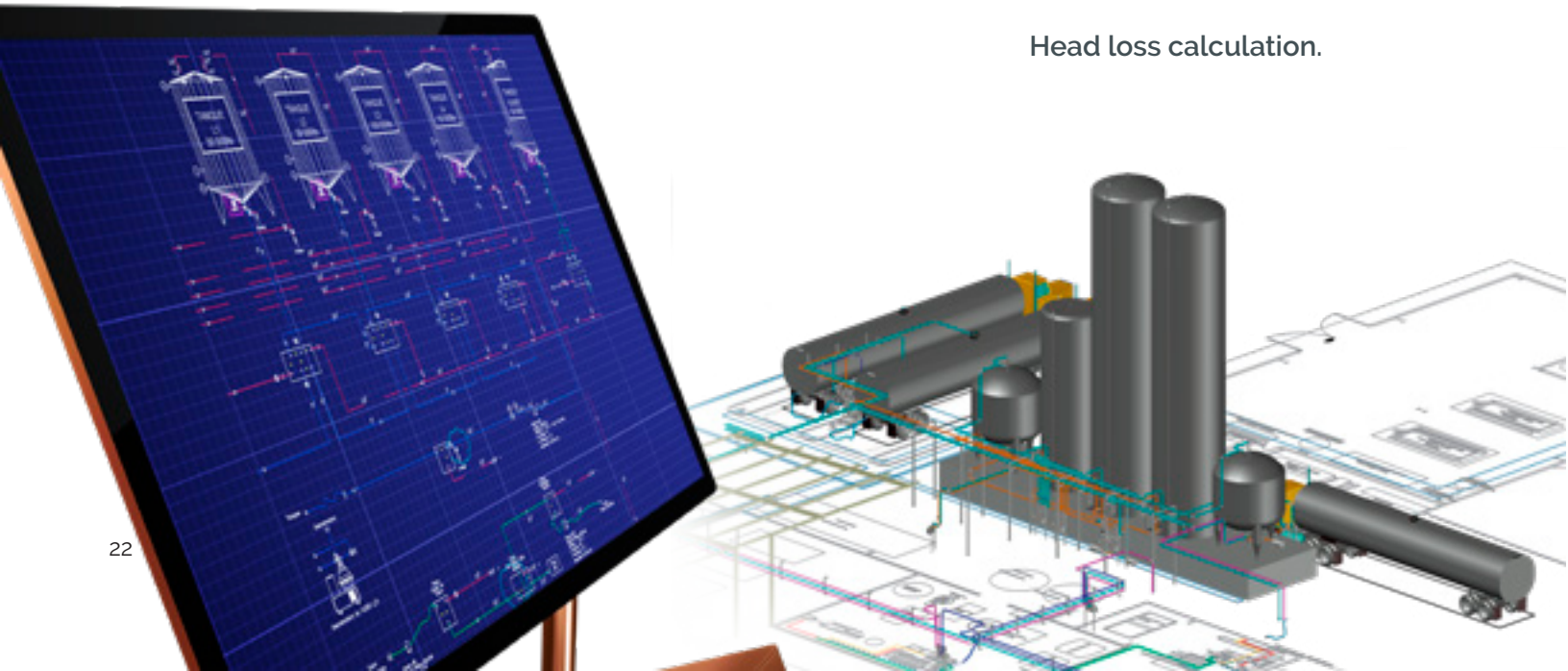

Electrical design

Our specialists oversee the selection of the appropriate equipment, always thinking of maximizing resource savings and overall efficiency.

The services related to the installation and control of industrial electricity that we offer are the following:

- Instrumentation diagrams
- Instrument specification.
- Design of power and control panels.
- Diagrams for control and automation equipment.
- Grounding systems.
- Lighting engineering.
- Short circuit calculations.
- Protection coordination studies.
- Arc Flash Studies.
- Line diagrams.
- Calculation memories.
- Equipment specification.
- Design of lightning rod systems.



Turnkey projects

We have a great team of professionals, and the Know-How to get in charge of all the stages of the projects. From the conception to the closure; carrying out the development of automation and electronic, electrical and process engineering.

Turnkey projects provide greater control over time, scope and budget.



Project and team management.



Detailed engineering documentation.



Obtaining required permits and licences.



Post-sale monitoring and guarantees.



Whether through agile, hybrid or traditional methodologies, our goal is the same: finish each project with maximum customer satisfaction.

Extensive experience in the food industry

It is the sector where we have the most experience, being "Dairy" and "Plant Based" the strength of the brand since its inception.

The team has successfully developed hundreds of projects in all areas of the factories: from the reception platforms of raw materials, going through pretreatments, separation processes, filling and discharge manifolds to tanks, preparation areas with macro and micro ingredients, mixing and flavoring, pasteurization or sterilization, HTST (flash pasteurization), UHT (ultra pasteurization), dilution, fermentation, storage, dosing and packaging.

Along with CIP / SIP (Clean In Place / Sterilization In Place) stations.

Our engineers are responsible for the selection and programming of valves, motors and control equipment for the integration of CIP lines.



Collaboration with the main OEMs, integrators and engineering companies

- Sequential application of the intercompany collaboration phases.
- Planning, development and monitoring.
- Development of functional specifications.
- Logistics coordination.
- Automation and IT development and integration.
- Quality control and safety assurance.
- FAT (Factory Acceptance Test).
- VSU (Vertical Start-Up).



Consultancy and specialized audit in automation



Process optimization to reduce product waste and energy.



Resolution of production and / or service problems.



Design, development and integration of methodologies.



Analysis and improvement of manufacturing processes.



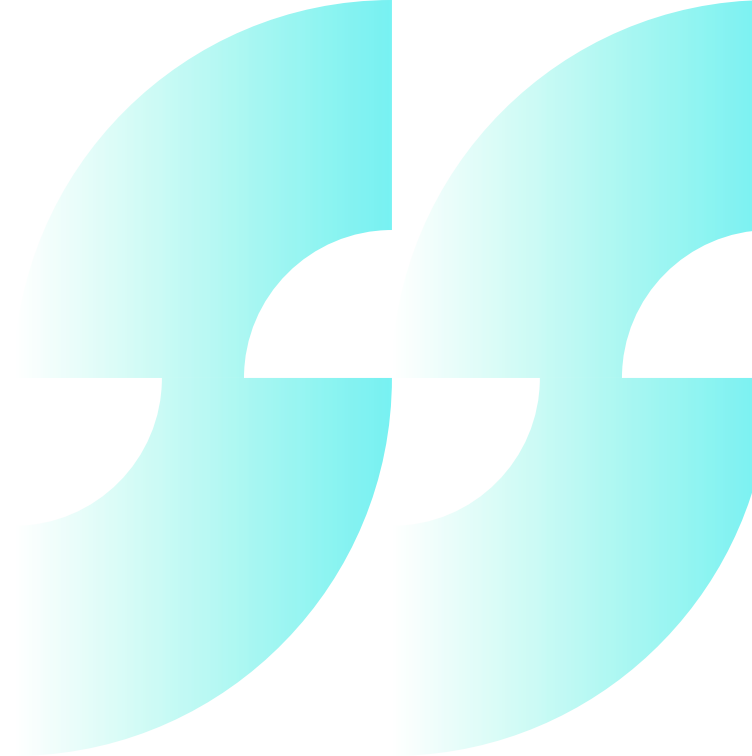

Autmix Industrial IT

Industrial IT
solutions

We are specialists committed to innovation, quality and service. Attributes that make us a leader in the integration between processes and sectors of factories through the use of information technologies.

Advantages



Technological innovation



Support 24/7



High quality equipment



Specialized technical support





Design and development of custom applications and servers

We design and develop applications with high levels of security, specialized to receive data from your processes; therefore, it is possible to monitor and consult the performance of your production remotely from your computer or mobile.

With the implementation of applications, store and access data in a reliable way, facilitating the loading of manufacturing parameters to achieve homogeneity in the quality and consistency of the final product.



Efficiently manage data distribution across your network using a server or server cluster depending on your needs.

Server → client.

Virtual servers.

File server.

Database server.

Proxy server.



Platforms



Web

The use of applications mounted in the cloud allows you to access information from anywhere, reducing costs in the design and assembly of traditional architectures.



Desktop

Design of custom desktop application architectures.



Mobile

Development of software for devices that allow remote and real-time monitoring.

Industrial networks and virtualization

Optimize information traffic between your computers quickly and efficiently reducing response times and avoiding disconnections with our network analysis and design service.

Learn about the topologies we design:

- Ethernet
- Token ring
- Apple talk
- FDDI
- ARCNET
- Ring
- Bus
- Star

We are experts in the main network protocols:

- EtherNet /IP
- DeviceNet
- ControlNet
- Ethernet ISO
- Profinet
- Profibus DP/PA
- Modbus
- Fieldbus
- Ethernet
- POWERLINK

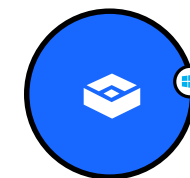

Reduce the installation and maintenance costs involved in the implementation and use of a server cluster for your process with our virtualization service, using:

**Autmix is an independent company and is neither affiliated with, nor authorized, sponsored, or approved by, Microsoft Corporation.*

Cybersecurity

Protect your investment and maintain your data secured.

We offer effective solutions to any emergency or risk in your surroundings. We have a comprehensive cybersecurity strategy for all types of companies and industries.



Evaluation and strategy

We assess your industry's situation and provide solutions to create an operational and preventive strategy.



Training

We know prevention is the best strategy to combat risks. We offer:

- » Constant updates.
- » Risk patterns identification.
- » Training to avoid vulnerabilities.



Defense services

We provide the best security management systems in physical environments and the cloud.



Service protection

We provide various technological tools for your needs:

- » Cryptographic implementations.
- » *Endpoint*
- » *IAM (Identity and Access Management)*.
- » Network security in OT and IoT environments.



Risk management

Identification, analysis, and action in risk situations. We act and make the best decisions before any exposition or damage.

We guarantee your tranquility and safety in the plant.



Virtual reality and augmented reality

We develop industrial applications of augmented reality that allow the visualization of data or additional information in order to help improve the experience of operators, engineers and supervisors when interacting with equipment and / or processes, recognizing faults, providing remote assistance and transmitting about what is being perceived in the real world, in real-time.



**Autmix is an independent company and is neither affiliated with, nor authorized, sponsored, or approved by, Microsoft Corporation.*

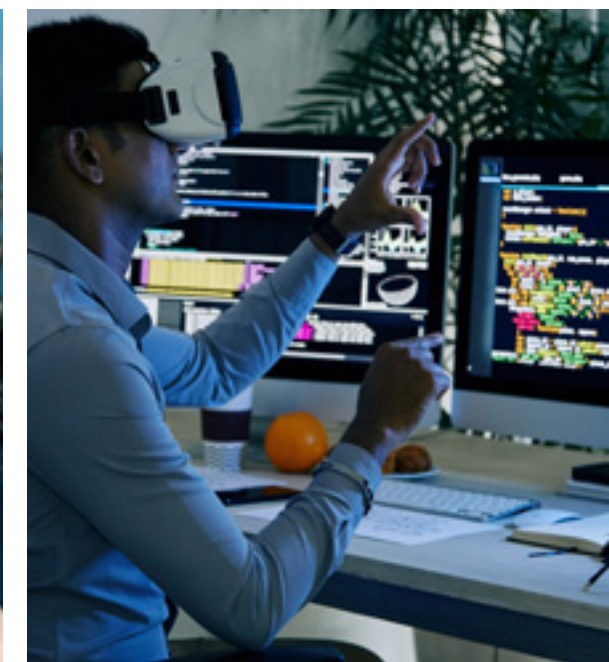

Productivity

Measurement systems KPIs

Measure the effectiveness of the process and the control system to allocate human and material resources more efficiently.

A some of the KPIs that we implement are:

- Good unit count
- Bad unit count
- Total output
- Slow production cycles

Systems for implementation OEE, MTTR, MTBF

Monitor, analyze, and improve with OEE (Overall Equipment Efficiency).

In industries, it is necessary to know in detail the production efficiency of the plant, whether of a specific equipment, process, production line or the entire manufacturing area.

We integrate the best software options for your factory:

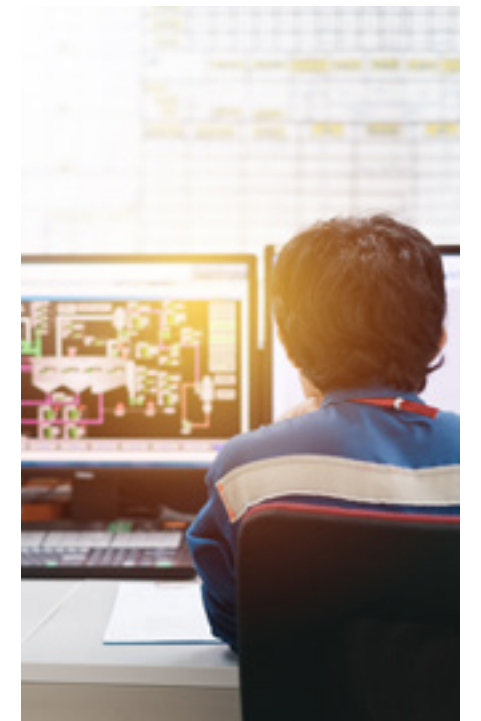

Some companies that have trusted our solutions

FOOD AND BEVERAGE



PHARMACEUTICAL



COSMETIC



CHEMICAL



SUGAR



OIL AND GAS



PAINT



WATER TREATMENT



CEMENTS AND MORTARS



MINING



PAPER





Autmix[®]
INDUSTRIAL
GROUP

autmix.com