

Building connections that last™



FlexHead® Flexible Fire Sprinkler Connections







THE FLEXHEAD ADVANTAGE **02**

INSTALLATION COMPARISON **03**

NFPA 13 CODE LANGUAGE &
SEISMIC QUALIFICATIONS **04**

PRODUCTS **06**

FRICTION LOSS DATA & SPECIFICATIONS **10**

FLEXHEAD CEILING DETAILS **12**

BRACKET SPECIFICATION SHEET **14**

FLEXHEAD COMMERCIAL PRODUCTS **15**

FLEXHEAD STANDARD SPECIFICATIONS **16**

ANVIL BRANDS **18**

CUSTOMER SERVICE CENTERS **20**

The Flexhead® Advantage

QUALITY

- **BEST CORROSION RESISTANCE**
Made from 100% 304 stainless steel
- **EXCELLENT FRICTION LOSS VALUES**
One-inch true-bore ID reducing the need to upsize mains and branch lines, 1¼" ID available
- **PRESSURE SURGE PROTECTION**
Fully braided connection improves pressure capability and prevents hose damage
- **HIGHEST MAXIMUM WORKING PRESSURE**
Available up to 300 PSI
- **NO O-RINGS OR GASKETS**
Welded connections reduce potential leak points at the inlet and outlet fitting
- **TIGHTEST THREAD TOLERANCES**
Outlet fitting threads are machined from solid bar stock reducing potential leaks at the sprinkler head fit-up
- **EXTRA STABILITY BRACKET**
A full 6-inch base to stabilize the sprinkler head during installation, pressurization or activation

FEATURES

- Is seismically qualified, eliminating the need for an oversized ring around the sprinkler head in seismic areas
- Has the same product design that is dual listed by both UL and FM
- Can be produced to meet all your project requirements
- Hoses have serial identification with complete audit tracking of finished goods
- Hose has comprehensive limited warranty backed by an A++ insurance company
- Offers a variety of flexible fire sprinkler connections, suspended ceilings, gypsum board ceilings, freezer, coolers, institutional applications, cleanroom and duct applications
- Offers 1.25" FlexHead® hose for superior friction loss numbers
- The 3" Tall MPT Bracket allows the sprinkler to install the FlexHead® system without touching the ceiling tile

FLEXHEAD®

Connect sprinkler heads to sub-mains at least four times faster.

FlexHead systems connect sprinkler heads to sprinkler sub-mains in about a quarter of the time it takes to install hard pipe. Expect even greater savings in retrofits, where FlexHead installs six to seven times faster than hard pipe.

Increase productivity with the ease of installation, no need to install hangers and there is no on-site assembly required. Every sprinkler connection is a finished, pre-constructed assembly, from the 1" pipe connector to the sprinkler head outlet. In addition, FlexHead provides seismic protection to sprinkler heads allowing for deflection during a seismic event.

NEW CONSTRUCTION COMPARISON

During a typical installation, a minimum of four FlexHeads can be installed in the same time it takes to do one hard-pipe.

Four Flexhead

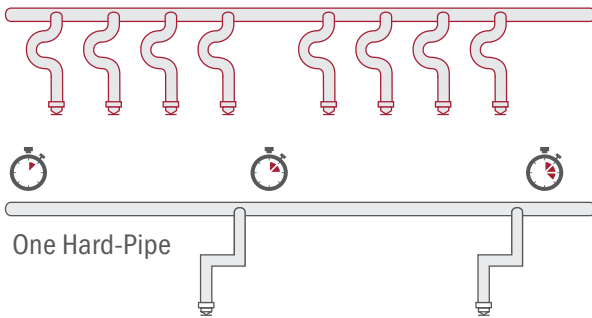

RETROFIT COMPARISON

During a typical installation, a minimum of six FlexHeads can be installed in the same time it takes to do one hard-pipe. Retrofits in less time.

Six Flexhead

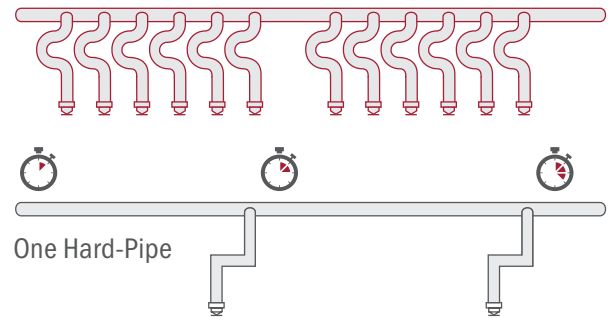

WANT PINPOINT LOCATIONS? NO PROBLEM.

The design makes it easy to accurately locate sprinkler heads every time. If the spec calls for center-of-tile placement, you can do it with ease. In fact, you get center-of-tile placement every install whether the spec calls for it or not. It takes one more headache out of specifying and bidding.

ACCOMMODATE FLOOR PLAN CHANGES.

Need to relocate sprinkler heads? No problem. With its built-in flexibility it's much easier to move heads to a new location to accommodate new layouts or uses of the space.

RETROFITS IN LESS TIME.

Need to comply to code in unsprinklered buildings? In contrast to costly and labor-intensive hard-pipe retrofits, FlexHead connections install in minutes in even the most restrictive spaces.

SHORTEN YOUR TIME TO OCCUPANCY.

Faster installation times help get end-users into their spaces more quickly—and get installers on their next projects faster. FlexHead connections virtually eliminate punch list items commonly found with hard-pipe armovers.

NFPA 13 CODE LANGUAGES & SEISMIC QUALIFICATION

NFPA 13 STANDARDS FOR INSTALLATION OF SPRINKLER SYSTEMS 2019

- 17.4.1.3.3* Flexible Sprinkler Hose Fittings
- 17.4.1.3.3.1 Listed flexible sprinkler hose fittings and their anchoring components intended for use in installations connecting the sprinkler system piping to sprinklers shall be installed in accordance with the requirements of the listing, including any installation instructions.
- 17.4.1.3.3.2 When installed and supported by suspended ceilings, the ceiling shall meet ASTM C635/C635M, *Standard Specification for the Manufacture, Performance, and Testing of Metal Suspension Systems for Acoustical Tile and Lay-In Panel Ceilings*, and shall be installed in accordance with ASTM C636/C636M, *Standard Practice for Installation of Metal Ceiling Suspension Systems for Acoustical Tile and Lay-In Panels*.
- 17.4.1.3.3.3* Where flexible sprinkler hose fittings exceed 6 ft (1.8 m) in length and are supported by a suspended ceiling in accordance with 17.4.1.3.3.2, a hanger(s) attached to the structure shall be required to ensure that the maximum unsupported length does not exceed 6 ft (1.8 m) .
- 17.4.1.3.3.4* Where flexible sprinkler hose fittings are used to connect sprinklers to branch lines in suspended ceilings, a label limiting relocation of the sprinkler shall be provided on the anchoring component.

Reproduced with permission of NFPA from NFPA 13, Standard on the Installation of Sprinkler Systems, 2019 edition. Copyright© 2018, National Fire Protection Association. For a full copy of NFPA 13, please go to www.nfpa.org. This material is not affiliated with nor has it been reviewed or approved by the NFPA.

FLEXHEAD® SATISFIES SEISMIC CODE REQUIREMENTS

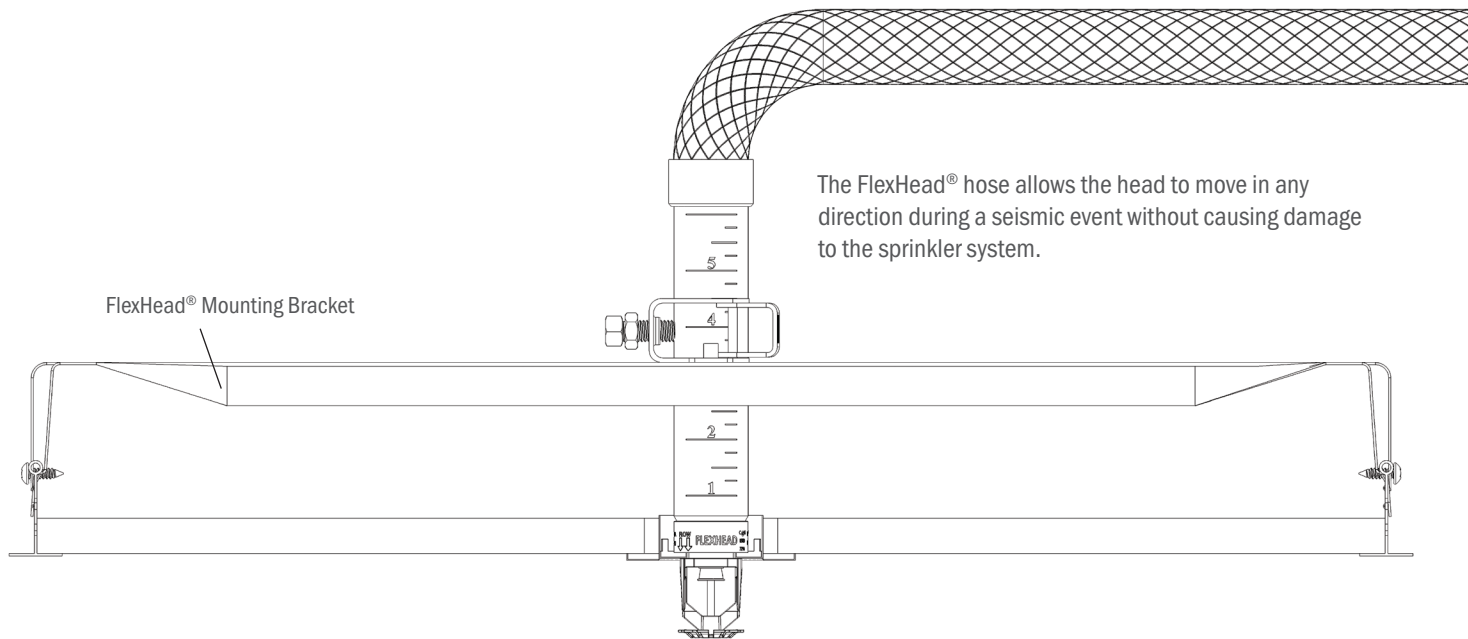

FlexHead® satisfactorily completed full-scale seismic qualification testing at the Structural Engineering Earthquake Simulation Laboratory located at the State University of New York at Buffalo. Tests were conducted using the International Code Council (ICC) acceptance criteria “ICC-ES AC-156 Seismic Qualification Testing of Nonstructural Components”.

- More than 90% of the states in the U.S. are adopting the International Building Code (IBC) that address, among other things, the installation of fire sprinkler systems in seismic zones.
- The latest version of the IBC defers to ASCE 7 and ASTM E580/580M-17 for the sprinkler/ceiling design in Seismic Design Categories C and D, E & F.
- In Seismic Design Category C, suspended ceilings are to be designed and installed in accordance with Ceilings & Interior Systems Construction Association (CISCA) recommendations for Zones 0-2; and sprinkler heads and other penetrations shall have a minimum of ¼ inch clearance on all sides.
- In Seismic Design Categories D, E & F, suspended ceilings are to be designed and installed in accordance with CISCA recommendations for seismic Zones 3 and 4 with some additional requirements. Except where rigid braces are used to limit lateral deflections, sprinkler heads and other penetrations shall have a 2-inch oversized ring, sleeve, or adapter through the ceiling to allow for free movement of at least 1 inch of ceiling movement in all horizontal directions.
- Flexible sprinkler connection provide characteristics that exceed the most stringent seismic code requirements. The flexibility of the hose allows the head to move with the ceiling in any direction during a seismic event without causing damage to the sprinkler system.

FLEXIBLE FIRE SPRINKLER CONNECTIONS

We invented the concept of Flexible Fire Protection™. All our flexible sprinkler pipe and connections are UL Listed and/or FM Approved.

THE ONLY PRODUCT THAT:

- Has undergone full-scale head deployment testing
- Is seismically qualified for use in Seismic Design Categories D, E & F
- Is made of 100% 304 stainless steel including end fittings
- Is fully welded without the need for o-rings or gaskets

FLEXHEAD®
TRUST THE ORIGINAL™

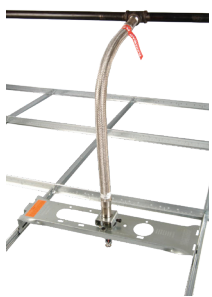
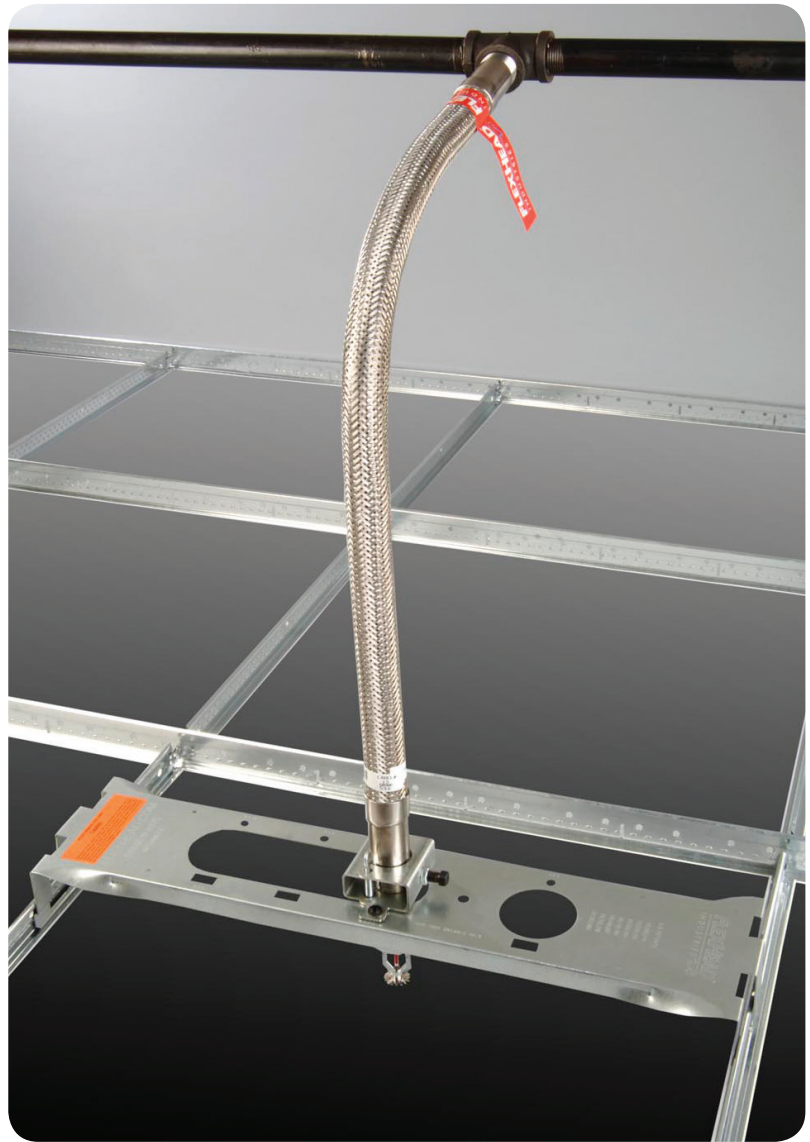

FLEXHEAD® FLEXIBLE FIRE SPRINKLER CONNECTIONS

- UL Listed/ FM Approved
- Undergone full-scale head deployment testing
- Seismically qualified for use in Seismic Design Categories C, D, E & F
- Made of 100% 304 stainless steel including end fittings
- Every FlexHead hose is leak tested before shipment
- Fully welded 304SS hose doesn't contain any O-rings or gaskets



INSTITUTIONAL FLEXIBLE FIRE SPRINKLER CONNECTIONS

- Available in hose lengths from 24" - 72"
Designed to be installed in concrete walls or ceiling penetrations
- Available with open hub UHO-3 bracket for easier installation
- Easy installation in tight spaces
- UL Listed / FM Approved



FLEXIBLE FIRE SPRINKLER CONNECTIONS

FlexHead® systems connect sprinkler heads to sub-mains at least four times faster than hard pipe. Delivers even greater savings in retrofits. All our flexible sprinkler pipe and connections are UL Listed and/or FM Approved.

TRUST THE ORIGINAL™

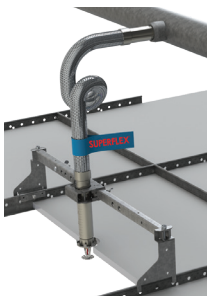

SUPERFLEX® FLEXIBLE FIRE SPRINKLER CONNECTIONS

- No need to measure or count the number of bends, 72" SuperFlex hose is UL listed for up to (12) bends
- Increased bends create more flexibility during installation
- All Welded, no o-rings
- Quick inspections and sign offs by AHJ's for final walkthrough
- Available with MPT (Multi-positional tail) mounting bracket. No need to touch the ceiling tile during installation.
- Also available with Adjustable ADO24BKT3 mounting bracket.
- UL Listed / FM Approved

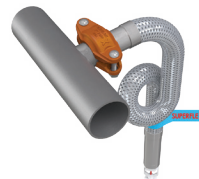

SUPERFLEX® FLEXIBLE FIRE SPRINKLER CONNECTION WITH PATENTED SLT TECHNOLOGY

- Fast and easy installation with 1" integrated SlideLOK® Coupling
- Comes fully assembled
- UL listed for 2" bend radius, up to 12 bends per hose* (72" hose)
- Eliminates taping or doping of threaded fittings
- Flexible design provides versatility for changes in plan
- Installs on a **standard 1"** Welded Outlet
- UL Listed / FM Approved



1.25" I.D. HOSE WITH BEST FLOW CHARACTERISTICS

- Best flow characteristics for flexible drops in the industry
- 1¼" NPT Standard, and 1¼" **SLT integrated coupling option available**
- Great for tenant improvement projects, similar flow characteristic to 1" pipe
- FM Approved

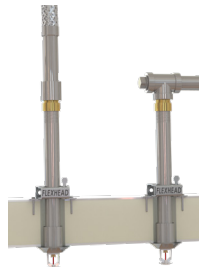

FLEXIBLE FIRE SPRINKLER DRY PENDENT SYSTEM

- Suitable for **wet sprinkler systems with a dry pendent sprinkler head** (Dry pendant sprinkler head not included)
- Mounts on the top of freezer or sidewall
- Moves and flexes along with the structure protecting the integrity of the freezer seal
- Now available with a Drain Tee
- FM Approved

FLEXIBLE FIRE SPRINKLER CONNECTIONS

We invented the concept of Flexible Fire Protection™. All our flexible sprinkler pipe and connections are UL Listed and/or FM Approved.

TRUST THE ORIGINAL™



NO TOUCH CEILING TILE TALL BRACKET MOUNTING SYSTEM (MPT24BKT1)

- Superior height allows the “MPT” to be mounted without pre-installing the ceiling tile and comes out of the box fully assembled at 24”
- Within seconds the MPT Bracket can be adjusted from 24” to 16” to 14 ½” in length accommodating numerous applications without additional fabrication
- Adjustable Open Hub allows for swift & accurate repositioning at the 1/4 points
- UL Listed / FM Approved



ARMSTRONG® TECHZONE™ BRACKET MOUNTING SYSTEM

- The mounting bracket is specifically designed to be compatible with the Armstrong®TechZone™ suspended ceiling systems
- FlexHead TechZone™ mounting bracelets allow for quick TechZone™ ceiling installations. The FlexHead TechZone™ system installs in a quarter of the time compared to typical black pipe armovers.
- Allows for rapid installation or relocation of sprinkler heads in suspended ceilings
- UL Listed / FM Approved

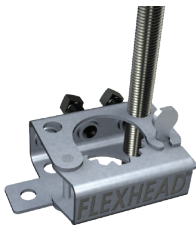

UHO-3 THREADED ROD INSTALLATION

- “Open Hub” design for quick and easy installation
- Can be installed with ¾” or ½” threaded rod attachments
- The ¾” rod is FM approved to be installed up to 4ft off the structure and the ½” threaded rod up to 6ft off the structure
- Good option for temporary fire protection
- Ideal for shell applications; easily transitions from UHO-3 to suspended ceiling bracket
- FM Approved

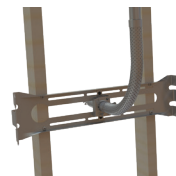

DRY WALL CEILING AND SIDEWALL INSTALLATION (AD016BKT3 & AD024BKT3)

- FlexHead AD016BKT3 and AD024BKT3 can be installed in hard ceilings or sidewall applications.
- For use with FlexHead hose model numbers 20XX, 20XXH, where XX designates hose length in inches.
- FM Approved

FLEXIBLE FIRE SPRINKLER CONNECTIONS

Whether your application is commercial, industrial, clean room, or institutional, FlexHead® flexible sprinkler systems can save you time and money by offering reliable, highly efficient, seismically qualified, and environmentally responsible products



DROP NIPPLE FLEXIBLE SPRINKLER CONNECTIONS FOR ANVIL-STRUT™

- Attach to structure with Anvil-Strut™ and pipe clamp
- Drop nipple with reducer (not included)
- Perfect for applications where you have a concrete deck above the ceiling which secures the flexible hose to the building structure.
- This model will have a 1 inch female outlet
- FM Approved



LOW-PROFILE FLEXIBLE FIRE SPRINKLER CONNECTIONS FOR ANVIL-STRUT™

- Perfect for applications where you have limited space
- The FlexHead Low-Profile Model uses traditional Anvil-Strut™ Channel (not included) to secure the FlexHead sprinkler hose to the building structure
- FM Approved



INDUSTRIAL/DUCT FLEXIBLE FIRE SPRINKLERS CONNECTIONS

- FlexHead flexible sprinkler systems have been protecting exhaust ducts in semi-conductor/electronics facilities for more than thirty years
- Quick installation, install in minutes
- No need for inspection port
- Available in Steel, FRP, Polypropylene, and PVC
- Flexible hoses allow for independent motion (sway) between duct and water main to compensate for duct vibration and during possible seismic activity—eliminating potential leaks.
- Allows for quick and easy inspection of sprinkler heads
- FM Approved



CLASS 100 CLEANROOM FLEXIBLE FIRE SPRINKLER CONNECTIONS

- Custom manufactured for “walkable” cleanroom ceiling systems in Class 100 cleanrooms.
- 100% stainless-steel, one-piece system is leak-tested prior to shipping
- Allows quick and easy relocation when floor plan changes due to reconfiguration of tool layout
- Allows for independent motion (sway) between ceiling grid and water main to accommodate filter vibration and during possible seismic activity.
- Eliminates potential leaks and protecting gel seals
- Eliminates ceiling stress/leaks due to miss-aligned hard-pipe installation
- FM Approved

FRICION LOSS DATA & SPECIFICATIONS

Model Number	Outlet Orifice Size	Hose Assembly Length	Minimum Bend Radius		Maximum Number of 90° Bends		Equivalent Length of 1in. Diameter Schedule 40 Pipe (Ft)						Max Rated Pressure		
			FM	UL	UL	FM	UL	FM						FM	LU
								5.6k-factor	8.0k-factor	11.2k-factor	14.0k-factor	16.8k-factor	22.4k-factor		
	in (cm)	in (mm)	in (mm)	in (mm)	in (mm)	in (mm)	Ft (mm)	Ft (mm)	Ft (mm)	Ft (mm)	Ft (mm)	Ft (mm)	Ft (mm)	PSI/Kpa	PSI/Kpa
SUPERFLEX® 1" INTERNAL DIAMETER (I.D.) HOSE SERIES (Data equivalent for all end connection 1" NPT, 1" Cut Groove and SLT)															
2036SF-50	½ (1.27)	36 (914)	7 (178)	2 (50.8)	5	2	30 (9.1)	16.2 (4.9)	16.9 (5.1)	11.5 (3.5)	-	-	-		
2048SF-50		48 (1219)			8	3	47 (14.3)	28.7 (8.7)	29.3 (8.9)	15.4 (4.7)	-	-	-		
2072SF-50		72 (1828)			12	4	71 (21.6)	53.9 (16.4)	54.3 (16.5)	23.2 (7)	-	-	-		
2036SF-75	¾ (1.90)	36 (914)	7 (178)	2 (50.8)	5	2	29 (8.8)	-	21.5 (6.5)	21.6 (6.5)	21.8 (6.6)	22 (6.7)	-		
2048SF-75		48 (1219)			8	3	44 (13.4)	-	30.5 (9.2)	30.6 (9.3)	31.1 (9.4)	30.8 (9.3)	-		
2072SF-75		72 (1828)			12	4	70 (21.3)	-	48.5 (14.7)	48.8 (14.8)	49.9 (15.2)	48.6 (14.8)	-		
FLEXHEAD STANDARD TALL 1" INTERNAL DIAMETER (I.D.) HOSE SERIES															
2024T-50	½ (1.27)	24 (610)	8 (200)	3 (76.2)	3	1	11 (3.4)	18.4 (5.6)	7.7 (2.3)	7.6 (2.3)	-	-	-	175 (1205)	175 (1205)
2036T-50		36 (914)			3	2	16 (4.9)	26.6 (8.1)	11.5 (3.5)	11.5 (3.5)	-	-	-		
2048T-50		48 (1219)			4	3	24 (7.3)	30.3 (9.2)	15.3 (4.6)	15.4 (4.7)	-	-	-		
2060T-50		60 (1524)			4	4	29 (8.8)	35.8 (10.9)	19.1 (5.8)	19.3 (5.8)	-	-	-		
2072T-50		72 (1828)			4	4	35 (10.7)	45.6 (13.9)	23.0 (7)	23.2 (7)	-	-	-		
2024T-75	¾ (1.90)	24 (610)	8 (200)	3 (76.2)	3	1	12 (3.7)	-	7.3 (2.2)	5.9 (1.8)	14.7 (4.5)	7.1 (2.1)	-	175 (1205)	175 (1205)
2036T-75		36 (914)			3	2	18 (5.5)	-	21.5 (6.5)	10.4 (3.1)	21.8 (6.6)	10.9 (3.3)	-		
2048T-75		48 (1219)			4	3	23 (7)	-	30.5 (9.3)	14.9 (4.5)	29 (8.8)	14.8 (4.5)	-		
2060T-75		60 (1524)			4	4	29 (8.8)	-	39.5 (12)	19.4 (4.5)	36.1 (11)	18.7 (5.6)	-		
2072T-75		72 (1828)			4	4	32 (9.8)	-	48.5 (14.7)	24.0 (7.3)	43.2 (13.1)	22.6 (6.8)	-		
FLEXHEAD® STANDARD TALL ELBOW 1" INTERNAL DIAMETER (I.D.) HOSE SERIES															
2024ET-50	½ (1.27)	24 (610)	8 (200)	3 (76.2)	3	1	19 (5.8)	26.4 (8.0)	6.8 (2)	7.4 (2.2)	-	-	-	175 (1205)	175 (1205)
2036ET-50		36 (914)			3	2	23 (7.0)	30.1 (9.2)	11.8 (3.6)	12.5 (3.8)	-	-	-		
2048ET-50		48 (1219)			4	3	27 (8.2)	33.8 (10.3)	16.9 (5.1)	17.6 (5.3)	-	-	-		
2060ET-50		60 (1524)			4	4	32 (9.8)	37.5 (11.4)	21.9 (6.6)	22.7 (6.9)	-	-	-		
2072ET-50		72 (1828)			4	4	35 (10.7)	41.2 (12.5)	27.0 (8.2)	27.8 (8.4)	-	-	-		
2024ET-75	¾ (1.90)	24 (610)	8 (200)	3 (76.2)	3	1	18 (5.5)	-	8.8 (2.6)	8.7 (2.6)	14.7 (4.5)	8.2 (2.5)	-	175 (1205)	175 (1205)
2036ET-75		36 (914)			3	2	23 (7.0)	-	25.5 (7.7)	14.2 (4.2)	21.8 (6.6)	13 (3.9)	-		
2048ET-75		48 (1219)			4	3	23 (7.0)	-	32.9 (10)	18.4 (5.6)	29 (8.8)	17.8 (5.4)	-		
2060ET-75		60 (1524)			4	4	29 (8.8)	-	40.6 (12.3)	22.7 (6.9)	36.1 (11.0)	22.6 (6.8)	-		
2072ET-75		72 (1828)			4	4	32 (9.8)	-	48.5 (14.7)	27.0 (8.2)	43.2 (13.1)	27.5 (8.3)	-		
FLEXHEAD® HIGH PRESSURE 1" INTERNAL DIAMETER (I.D.) HOSE SERIES															
2024H-50	½ (1.27)	24 (610)	8 (200)	3 (76.2)	3	2	11 (3.4)	18.4 (5.6)	7.7 (2.3)	7.6 (2.3)	-	-	-	300 (2068)	300 (2068)
2036H-50		36 (914)			3	3	16 (4.9)	26.6 (8.1)	11.5 (3.5)	11.5 (3.5)	-	-	-		
2048H-50		48 (1219)			4	4	24 (7.3)	30.3 (9.2)	15.3 (4.6)	15.4 (4.7)	-	-	-		
2060H-50		60 (1524)			4	4	29 (8.8)	35.8 (10.9)	19.1 (5.8)	19.3 (5.8)	-	-	-		
2072H50		72 (1828)			4	4	35 (10.7)	45.6 (12.5)	23.0 (7)	23.2 (7)	-	-	-		
2024ET-75	¾ (1.90)	24 (610)	8 (200)	3 (76.2)	3	1	12 (3.7)	-	14.7 (4.5)	6.8 (2.0)	14.7 (4.5)	8.2 (2.1)	-	300 (2068)	300 (2068)
2036ET-75		36 (914)			3	2	18 (5.5)	-	21.5 (6.5)	11.4 (3.4)	21.8 (6.6)	10.9 (3.3)	-		
2048ET-75		48 (1219)			4	3	23 (7.0)	-	30.5 (9.2)	16.0 (5.1)	29 (8.8)	14.8 (4.5)	-		
2060ET-75		60 (1524)			4	4	29 (8.8)	-	39.5 (12)	20.6 (6.2)	36.1 (11.0)	18.7 (5.7)	-		
2072ET-75		72 (1828)			4	4	32 (9.8)	-	48.5 (14.7)	25.3 (7.7)	43.2 (13.1)	22.6 (6.5)	-		

FRICITION LOSS DATA & SPECIFICATIONS (CONT'D)

Model Number	Outlet Orifice Size	Hose Assembly Length	Minimum Bend Radius		Maximum Number of 90° Bends		Equivalent Length of 1in. Diameter Schedule 40 Pipe (Ft)						Max Rated Pressure		
			FM	UL	UL	FM	UL	FM						FM	LU
								5.6k-factor	8.0k-factor	11.2k-factor	14.0k-factor	16.8k-factor	22.4k-factor		
	in (cm)	in (mm)	in (mm)	in (mm)	in (mm)	in (mm)	Ft (mm)	Ft (mm)	Ft (mm)	Ft (mm)	Ft (mm)	Ft (mm)	Ft (mm)	PSI/Kpa	PSI/Kpa
FLEXHEAD® HIGH PRESSURE ELBOW 1" INTERNAL DIAMETER (I.D.) HOSE SERIES															
2024HE-50	½ (1.27)	24 (610)	8 (200)	3 (76.3)	3	2	19 (5.8)	14.7 (4.5)	6.8 (2)	7.4 (2.2)	-	-	-	300 (2068)	300 (2068)
2036HE-50		36 (914)			3	3	23 (7.0)	21.8 (6.6)	11.8 (3.6)	12.5 (3.8)	-	-	-		
2048HE-50		48 (1219)			4	4	27 (8.2)	29.0 (8.8)	16.9 (5.1)	17.6 (5.3)	-	-	-		
2060HE-50		60 (1524)			4	4	32 (9.8)	36.1 (11)	21.9 (6.6)	22.7 (6.9)	-	-	-		
2072HE-50		72 (1828)			4	4	35 (10.7)	43.2 (13.1)	27.0 (8.2)	27.8 (8.4)	-	-	-		
2024HE-75	¾ (1.90)	24 (610)	8 (200)	3 (76.3)	3	2	18 (5.5)	-	14.7 (4.5)	-	14.7 (4.5)	8.2 (4.5)	-	300 (2068)	300 (2068)
2036HE-75		36 (914)			3	3	23 (7.0)	-	25.2 (7.7)	26 (7.9)	21.8 (6.6)	13 (3.9)	-		
2048HE-75		48 (1219)			4	4	23 (7.0)	-	32.9 (10)	33 (10)	29 (8.8)	17.8 (5.4)	-		
2060HE-75		60 (1524)			4	4	29 (8.8)	-	40.5 (12.3)	40 (12.2)	36.1 (11.0)	22.6 (6.8)	-		
2072HE-75		72 (1828)			4	4	32 (9.8)	-	48.5 (14.8)	47 (14.3)	43.2 (13.1)	27.5 (8.3)	-		
FLEXHEAD® DRY PENDENT SYSTEM 1" INTERNAL DIAMETER (I.D.) HOSE SERIES															
2024-DPS	1 (2.54)	24 (610)	7 (200)	-	-	1	-	18.4 (5.6)	7.7 (2.3)	7.6 (2.3)	-	7.1 (2.1)	10.7 (3.3)	-	175 (1205)
2036-DPS		36 (914)			-	2	-	26.6 (8.1)	11.5 (3.5)	11.5 (3.5)	-	10.9 (3.3)	15.1 (4.6)		
2048-DPS		48 (1219)			-	3	-	30.3 (9.2)	15.3 (4.7)	15.4 (4.7)	-	14.8 (4.5)	21.5 (6.5)		
2060-DPS		60 (1524)			-	4	-	35.8 (10.9)	19.1 (5.8)	19.3 (5.9)	-	18.7 (5.7)	25.3 (7.7)		
2072-DPS		72 (1828)			-	4	-	45.6 (13.9)	23.0 (7)	32.2 (7)	-	22.6 (6.9)	26.9 (8.1)		
FLEXHEAD® INSTITUTIONAL 1" INTERNAL DIAMETER (I.D.) HOSE SERIES															
2024I	½ (1.27)	24 (610)	8 (200)	3 (76.2)	3	1	11 (3.4)	18.4 (5.6)	-	-	-	-	-	175 (1205)	175 (1205)
2036I		36 (914)			3	3	16 (4.9)	26.6 (8.1)	-	-	-	-	-		
2048I		48 (1219)			4	4	24 (7.3)	30.3 (9.2)	-	-	-	-	-		
2060I		60 (1524)			4	4	29 (8.8)	35.8 (10.9)	-	-	-	-	-		
2072ET-50		72 (1828)			4	4	35 (10.7)	45.6 (13.9)	-	-	-	-	-		
2024I	¾ (1.90)	24 (610)	8 (200)	3 (76.2)	3	1	12 (3.7)	-	-	-	11.6 (3.5)	-	-	175 (1205)	175 (1205)
2036I		36 (914)			3	2	18 (5.5)	-	-	-	16 (4.9)	-	-		
2048I		48 (1219)			4	3	23 (7.0)	-	-	-	17.9 (5.4)	-	-		
2060I		60 (1524)			4	4	29 (8.8)	-	-	-	24.7 (7.5)	-	-		
2072I		72 (1828)			4	4	32 (9.8)	-	-	-	28.9 (8.8)	-	-		

Notes:

Model Numbers:

- "SF" designates SuperFlex® Hose series.
- "ESF" designates SuperFlex® Elbow Hose series.
- "E" designates elbow drop hose series
- "T" designates straight tall style hose
- "ET" designates elbow tall style hose series.
- "H" designates high pressure 300psi working pressure hose series.
- "HE" designates high pressure 300psi elbow hose series.
- "DPS" designates dry pendant system.
- "DT" designates drain tee hose series used in dry pendent/freezer application.
- "SLT" designates SlidelOK® technology.
- "DPS" and "DT" models are approved for use in cold storage application (Freezer, Cold Chamber) and combine an approved flexible sprinkler hose and an approved dry pendent sprinkler. UHO-1 or UHO-3 is required to connect the flexible sprinkler hose to the dry sprinkler.
- "I" indicates institutional flexible hose.
- "A" indicates models for use with Amerlux Ceiling System.
- "50" designates 1/2" Outlet Hose series. The "75" designates 3/4" Outlet Hose series. Inlet size 1".
- Max Ambient Temperature Rating on all model numbers are 300° F (148° C).
- Equivalent lengths are shown with maximum number of 90° bends at the minimum bend radius per agency. 2-45° or 3-30° bend equal 1-90° bend. Different values were obtained by FM and UL due to the difference in minimum bend radius, testing protocol and calculation methods. Please see individual standards for more information relative to Friction Loss (equivalent length of pipe).
- All hoses require a minimum of one bend for installation. Bend radius tool available for 3" bend "T" hose, "SF" hose does not require bend radius tool.
- FM equivalent length calculation includes Sprinkler Head Friction Loss.
- See listing(s) approval agency for the latest approval details.
- Friction loss data and specification of SuperFlex series include all end connection such as 1" NPT, 1" cut groove, and SLT. Specify end connection when ordering.

FLEXHEAD® CEILING DETAIL

SUSPENDED CEILING DETAIL

MPO24BKT2 Bracket

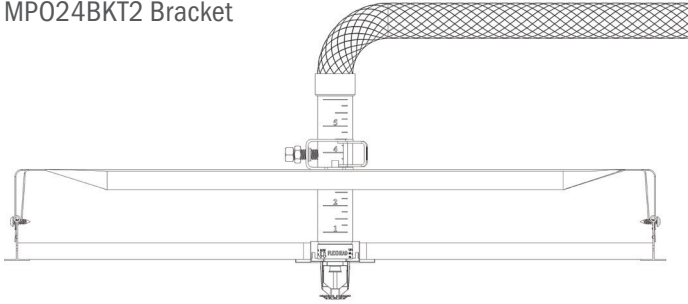

MPT24BKT1 Bracket

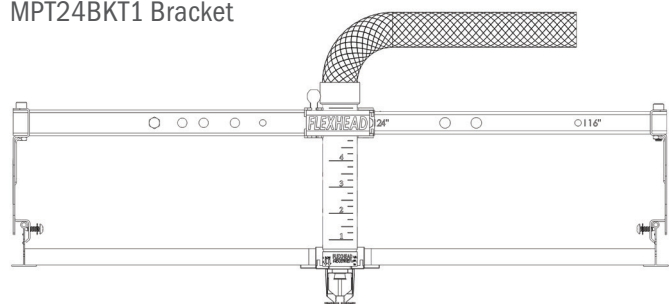

* Allows for bracket installation without pre-installing the ceiling tile

GYPSON BOARD HARD CEILING DETAIL

MPO24BKT2, ADO24BKT3 & ADO16BKT3 Brackets

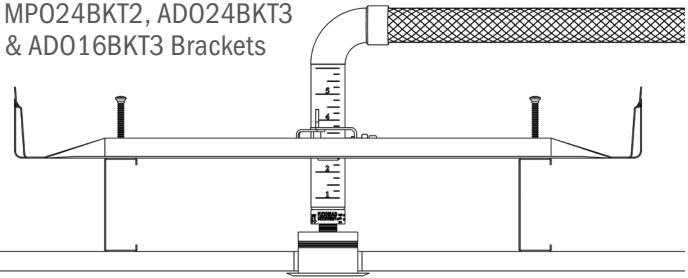

MPT24BKT1 Bracket

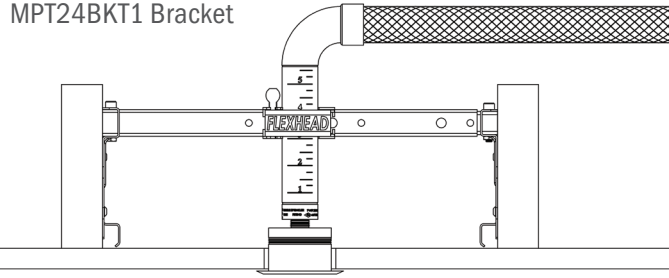

Each FM approved and UL listed unit is ready to install, pressure- and leak-tested, and comes complete with a flexible stainless steel hose and mounting bracket with adjustable hub.

FLEXHEAD® STANDARD HOSE 3" BEND RADIUS PER UL GUIDELINES (2 BENDS SHOWN)*

FLEXHEAD® STANDARD HOSE SHOWN WITH 3 BENDS

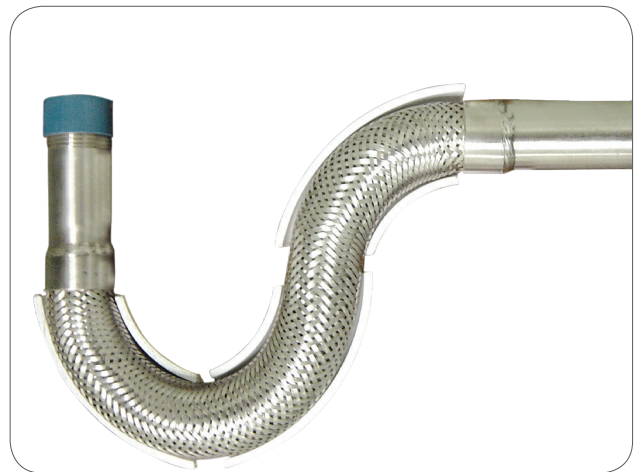
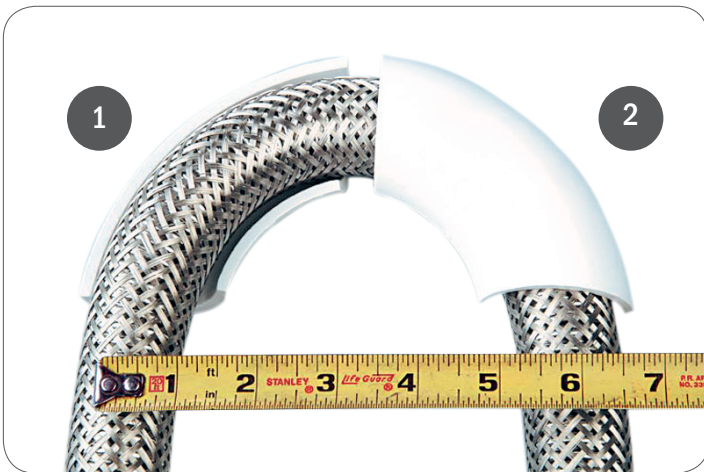

* Notes: SuperFlex® has a 2" bend radius. For more information on SuperFlex® specification refer to page 10.

FLEXHEAD® CEILING DETAIL

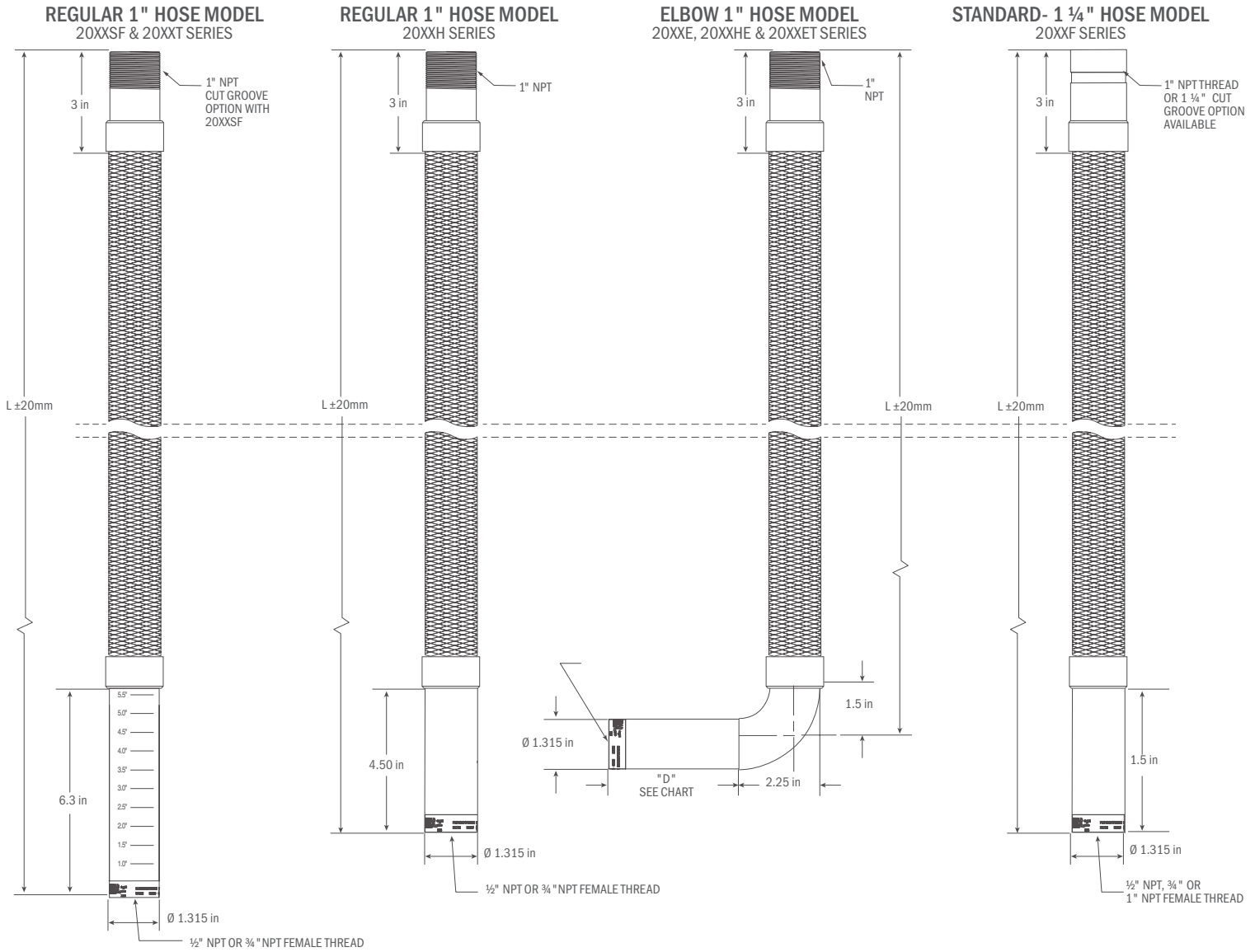

MODEL #	"Hose Assembly (L) Length Inches (mm)"	"Drop "D" Size (Inches)"
2024E/2024HE	24 (610)	1.5, 3.0, & 4.0
2036E/2036HE	36 (914)	
2048E/2048HE	48 (1219)	
2060E/2060HE	60 (1524)	
2072E/2072HE	72 (1828)	
2024ET	24 (610)	5.71
2036ET	36 (914)	
2048ET	48 (1219)	
2060ET	60 (1524)	
2072ET	72 (1828)	

BRACKET SPECIFICATION SHEET

MODEL MP024BKT2

Multiport Design (For use with T-bar and Metal Stud Applications)

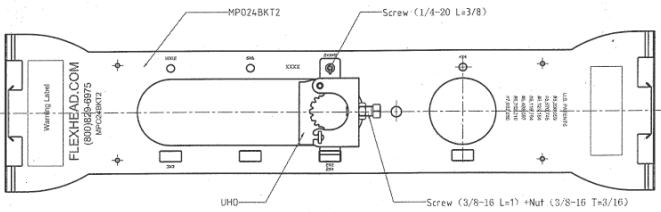

MODEL AD016BKT3, AD024BKT3, AD030BKT3, & AD048BKT3

Adjustable Design (For use with T-bar, Metal Stud and Chicago Grid Applications): standard sizes are 16", 24", 30" and 48" long

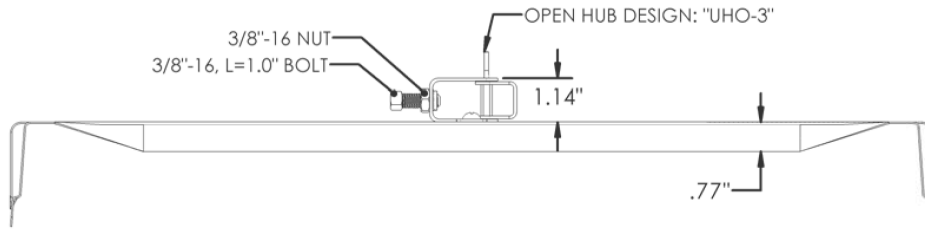
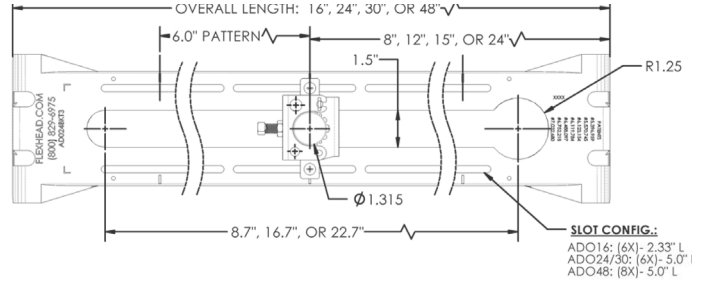

MODEL MPT24BKT1

Multi-Position Tall Bracket (For use with T-bar, Wood and Metal Studs): 24" standard size collapsible to 14.5" and 16" long.

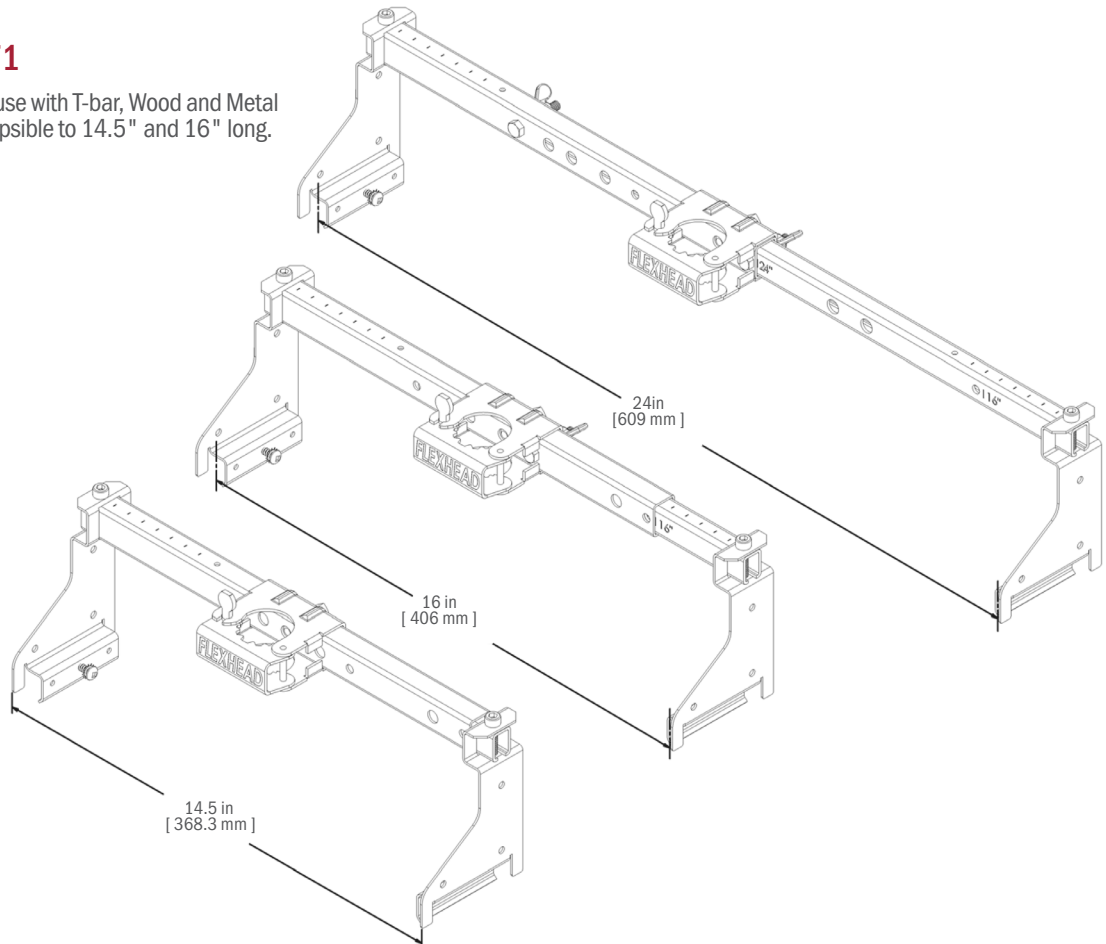

FLEXHEAD® COMMERCIAL PRODUCTS

STANDARD FLEXHEAD® HOSE LENGTHS: 24", 36", 48", 60" AND 72"

24", 36", 48", 60", and 72" hose lengths, Rated working pressure 175psi, optional 300psi. Standard 1" I.D., optional 1¼" I.D.

24", 36", 48", 60", and 72" hose lengths. Rated working pressure 175psi, optional 300psi.

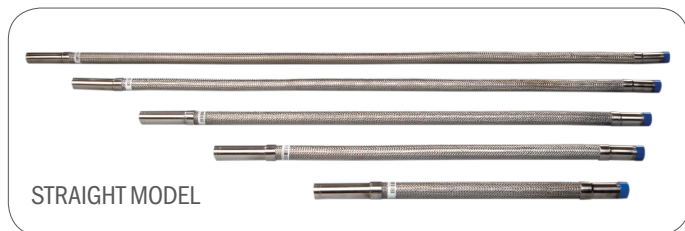

SUPERFLEX® HOSE LENGTHS: 36", 48", AND 72"

MODEL MP024BKT2

24" Multiport Bracket for T-bar Grid or Metal Stud applications. 6" stable mounting bracket.

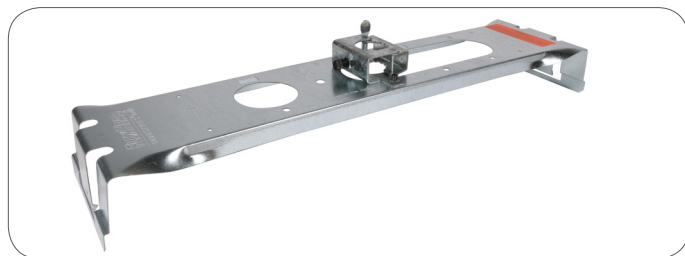

MODELS AD016BKT3, AD024BKT3, AD030BKT3 & AD048BKT3

16", 24", 30", 48" Adjustable Bracket for T-bar Grid, Chicago Grid or Metal Stud applications.

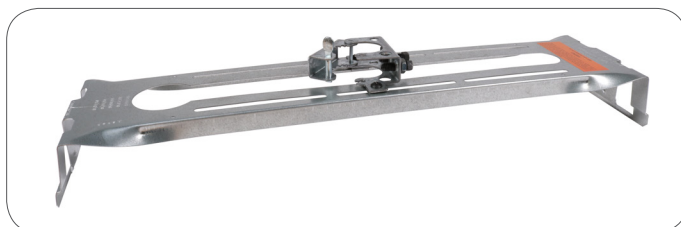

MODEL AD024BKT3 WITH BKT-HTA

Hat Channel Bracket System for Metal Stud or Hat Channel applications.

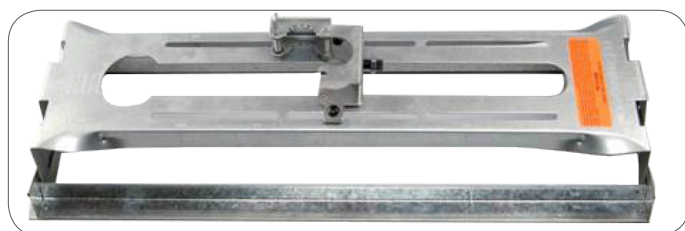

MODEL MPT24BKT1

24" Multi-Position Tall Bracket, collapses to 14 ½" and 16". Installs in suspended ceilings without touching the ceiling tiles.

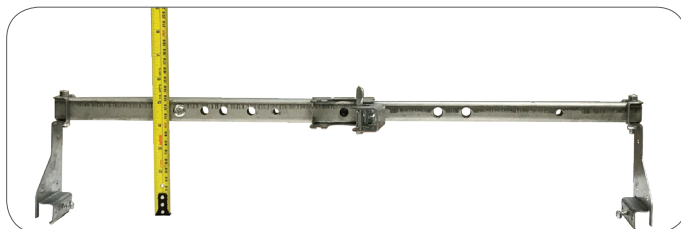

MODEL UHO-3

Designed for quick and easy installation. Ideal for shell applications. Can be installed with ¾" threaded rod up to 4' off structure and with ½" threaded rod up to 6' off structure.

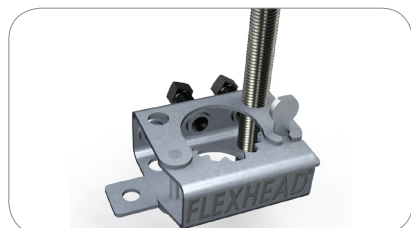

MODEL SP06TZBKT2

Armstrong® TechZone Ceiling Bracket for use with Armstrong TechZone Ceiling systems. Available in 6" widths.



MODEL 20XX-DPS-UHO-3

Dry Pendant System for Freezer and Cold Storage applications

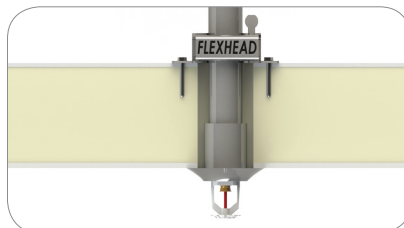

FLEXHEAD® STANDARD SPECIFICATIONS

DIVISION 21 MECHANICAL – SECTION 15300 FIRE PROTECTION PIPING

FLEXIBLE SPRINKLER HOSE FITTINGS FOR FIRE PROTECTION SERVICE

A. Manufacturer: FlexHead; Brand of Anvil International

B. Contact: 160 Frenchtown Rd, North Kingstown RI 02852 ; Telephone: (800) 829-6975; Email: FlexHeadsales@anvilintl.com; website: www.flexhead.com & www.anvilintl.com

1. Substitutions: No substitutions allowed.

C. Description:

1. Regulatory Requirements: Provide flexible stainless steel hose fittings that comply with the following requirements:
 - a. In accordance with General Requirements contained in Division 1 of specification.
 - b. In accordance with NFPA 13.

D. Performance Criteria: Comply with the following to suit project requirements:

1. FM 1637 Approval Standard for Flexible Sprinkler Hose with Threaded End Fittings.
2. UL 2443 Standard for Flexible Sprinkler Hose with Fittings for Fire Protection Service
3. ICC-ES AC-156 Acceptance Criteria for Seismic Qualification by Shake-Table Testing of Nonstructural Components and Systems

E. Materials: FlexHead Commercial Sprinkler Connections

1. FlexHead flexible stainless steel hose assemblies:

- a. Straight Hose Assembly Lengths: {2ft length, Model #2024T, 2024SF} {3ft length, Model #2036T, 2036SF} {4ft length, Model #2048T, 2048SF} {5ft length, Model #2060T, 2060SF} {6ft length, Model #2072T, 2072SF}.
 1. {½ inch} {¾ inch} outlet.
 2. {175 psi} {300 psi} maximum rated pressure.
 3. Fully welded non-mechanical fittings, braided, 100% leak-tested, with a minimum 1 inch true-bore internal corrugated hose diameter made of 100% 304 stainless steel braid, hose and end fittings. 1" NPT, 1" cut groove, or SLT end connection with 74FP SlideLOK®.
- b. Elbow Hose Assembly Lengths (For use in confined spaces): {2ft length, Model #2024E, 2024ET} {3ft length, Model #2036E, 2036ET} { 4ft length, Model #2048E, 2048ET} {5ft length, Model #2060E, 2060ET} { 6ft length, Model #2072E, 2072ET}
 1. {½ inch} {¾ inch} outlet.
 2. {175 psi} {300psi} maximum rated pressure.
 3. Fully welded non-mechanical fittings, braided, leak-tested with minimum 1 inch true-bore internal corrugated hose diameter made of 100% 304 stainless steel including end fittings.

2. FlexHead Ceiling Bracket: Direct attachment type having integrated ends positively attached to the ceiling using screws and attachment hub with set screw for attaching and adjusting flexible hose.

APPLICABLE STANDARDS

American Society of Civil Engineers (ASCE) -SEI/ASCE 7-05, Section 13.5.6 Suspended Ceilings

ASTM INTERNATIONAL

- ASTM C635 Standard Specification for the Manufacture, Performance, and Testing of Metal Suspension Systems for Acoustical Tile and Lay-in Panel Ceilings
- ASTM C636 Standard Practice for Installation of Metal Ceiling Suspension Systems for Acoustical Tile and Lay-In Panels
- FM Global Technologies LLC (FM) - FM Class Number 1637 Approval Standard for Flexible Sprinkler Hose with Threaded End Fittings

INTERNATIONAL CODE COUNCIL (ICC)

- ICC International Building Code (IBC), 2006
 - Section 803.9 Acoustical Ceiling Systems
 - Section 1613 Earthquake Loads

NATIONAL FIRE PROTECTION ASSOCIATION (NFPA)

- NFPA 13 Standard for the Installation of Sprinkler Systems
- NFPA 13D Standard for the Installation of Sprinkler Systems in One- and Two-Family Dwellings and Manufactured Homes
- NFPA 13R Standard for the Installation of Sprinkler Systems in Residential Occupancies up to and Including Four Stories in Height Underwriters Laboratories, Inc. (UL) - UL 2443 Standard for Flexible Sprinkler Hose with Fittings for Fire Protection Service

APPROVALS

Underwriters Laboratories, Inc. (UL) - UL Listed, VENF. EX5269, Flexible Sprinkler Hose Fitting

PHYSICAL/CHEMICAL PROPERTIES

Test reports are available to design professionals upon request.

PREPARATORY WORK

Installation should only be performed by qualified and licensed technicians in the fire protection field. Consult NFPA, FM, UL and state and local guidelines prior to installation.

METHODS

Each FlexHead ceiling sprinkler connection includes a mounting bracket and a 1-piece, leak tested FlexHead sprinkler drop.

Attach the bracket to the t-bar ceiling grid; then attach the FlexHead sprinkler to the sub-main. Secure the sprinkler to the bracket. Test installation of sprinkler system for any leaks per NFPA guidelines.

BUILDING CODES

Current data on building code requirements and product compliance may be obtained from the manufacturer's technical support specialists. Installation must comply with the requirements of applicable local, state and national code jurisdictions.

COST

Budget installed cost information may be obtained from the manufacturer upon request.

MAINTENANCE

Contact the manufacturer for complete maintenance information.

TECHNICAL SERVICES

Design assistance and technical support are available upon request from the manufacturer's trained staff.

FILING SYSTEMS

- MANU-SPEC®
- Additional product information is available from the manufacturer upon request

PRECAUTIONS

Consult the manufacturer's installation instructions for complete installation information. Failure to follow the cited instructions may cause personal injury. During maintenance or inspection of FlexHead product, the facility fire protection system must be inactive. Do not attempt relocation or maintenance of FlexHead product while fire protections system is live.

DISCLAIMER

- It is the responsibility of the system designer to verify suitability of 300-series stainless steel flexible hose for use with the intended fluid media within the piping system and external environments. The effect of chemical composition, pH level, operating temperature, chloride level, oxygen level, and flow rate on 300-series stainless steel flexible hose must be evaluated by the material specifier to confirm system life will be acceptable for the intended service.
- Failure to follow these instructions could cause product failure, resulting in serious personal injury and/or property damage.

About ASC Engineered Solutions

ASC Engineered Solutions is defined by quality—in its products, services and support. With more than 1,400 employees, the company’s portfolio of precision-engineered piping support, valves and connections provides products to more than 4,000 customers across industries, such as mechanical, industrial, fire protection, oil and gas, and commercial and residential construction. Its portfolio of leading brands includes ABZ Valve®, AFCON®, Anvil®, Anvil EPS, Anvil Services, Basic-PSA, Beck®, Catawissa, Cooplet®, FlexHead®, FPPI®, Gruvlok®, J.B. Smith, Merit®, North Alabama Pipe, Quadrant®, SCI®, Sharpe®, SlideLOK®, SPF® and SprinkFLEX®. With headquarters in Commerce, CA, and Exeter, NH, ASC also has ISO 9001:2015 certified production facilities in PA, TN, IL, TX, AL, LA, KS, and RI.



asc-es.com

Building connections that last™

